

How to Obtain a Building Permit For

POST FRAME BUILDINGS

**DETACHED GARAGES, RESIDENTIAL ACCESSORY STRUCTURES AND
AGRICULTURAL BUILDINGS**



MIAMI COUNTY, KANSAS

BUILDING INSPECTION DEPARTMENT

201 South Pearl Street Paola, Kansas 66071- 1777

Phone: (913) 294-4145

comdev@miamicountyks.org

www.miamicountyks.org

*Miami County's Mission is to provide the Community with professional services and effective use of resources through responsive, interactive and progressive government;
To safeguard community trust and funding; and
To promote and enhance the highest possible quality of life, while respecting individual rights and human dignity.*

"This institution is an equal opportunity provider and employer."

INTRODUCTION

Several types of structures are commonly utilized for detached residential accessory and agricultural buildings. The three most common types of structures are conventional light wood framing, post frame construction and rigid steel frame structures.

Each of these structures have unique construction features that need to be shown on the plans that are required to be submitted as a part of a building permit application. This document will outline the details and specifications that need to be shown on the plans for buildings utilizing the post frame construction requirements of the International Residential Code.

HOW TO GET STARTED

The following preliminary issues may need to be addressed prior to an application for a building permit .

- **Zoning:**

- Is the property zoned for how I intend to use my building?**

- If the intended use of a building is planned for anything other than normal residential accessory or agricultural use, you should contact the Miami County Planning Department at 913-294-9553 to discuss the proposed use. If the intended use is for any type of commercial or industrial activity including the storage of contractor's equipment, commercial trucks, or the repair or servicing of commercial equipment may require special zoning.

- **Wastewater Treatment:**

- If a bathroom or any plumbing fixtures, including floor drains, that will discharge any wastewater are planned to be installed, contact the Miami County Environmental Health Department at (913) 294- 4117 to discuss what type of wastewater treatment system is best suited for your building and an explanation of design and permitting guidelines for the system.

- **Highway Entrance Permit:**

- The location and construction of a new or existing entrance to a property off of county roadways is required to be approved before the construction of a new entrance is started or before a building permit is issued.

An application for a new driveway entrance or approval of an existing driveway entrance may be made either prior to or at the same time as applying for a building permit. A \$50.00 processing fee is due at the time the application for the entrance permit is made. Application for a highway entrance permit can be made at the building inspection office in the Miami County Administration Building.

After a site inspection of the proposed entrance location is made, the Road and Bridge Department will provide an estimated cost of construction. If an applicant chooses to have the Road and Bridge Department construct the new entrance, the construction costs shall be paid before installation will begin.

If applicants wish to construct the entrance themselves or contract with a private entity, a cash bond with the amount to be determined by the Road and Bridge Department shall be made prior to the start of construction. The Road and Bridge Department will refund the bond upon final approval of the installation of the highway entrance.

AVOID THE MOST COMMON MISTAKES

By avoiding some simple mistakes that are found during the review of plans and documents, unnecessary delays in obtaining your building permit can be prevented. Some of the most common mistakes are described as follows:

1. Site Plan not prepared in accordance with required standards. The site plan standard available from the Planning and Zoning Department should be followed closely.
2. Truss design plans not provided. Truss plans that have been sealed by an engineer are required. However, for the permit application truss shop drawings that are not sealed will be accepted with the sealed drawings being submitted prior to the truss installation beginning.
3. Licensed contractors. Miami County requires that any general, electrical, plumbing, mechanical, foundation, roofing or site utility contractor hold a valid contractor license. A letter from the licensed contractors that are used on a project verifying that they have agreed to work on the project must accompany each permit application.
4. Work performed exceeds the scope of work covered by permit. All work that is planned to be performed, including any interior partitions or any electrical, plumbing or heating and cooling systems, should be detailed on the permit application and the plans in accordance with the requirements of this guideline. Any work that is observed during inspections that is not included in the scope of work covered by the permit will result in a Stop Work Order being issued until the proper permits have been secured.

WHAT IS THE MINIMUM INFORMATION NEEDED TO APPLY FOR A BUILDING PERMIT?

In order for a permit application to be considered acceptable for review the following information shall be provided:

1. A completed building permit application form with all requested information provided.
2. A copy of the deed to the property with a full legal description included.
3. A completed highway entrance permit application.
4. Signed letters, copies of contracts or affidavits from each contractor that is listed on the permit application questionnaire. If the property owner intends to perform any work for which a license is required, an affidavit on a form provided by our office shall be completed and submitted with the permit application.
5. An affidavit for use of accessory building on a form provided by our office shall be completed and be submitted with the permit application.
6. Two (2) site plans prepared in accordance with Planning and Zoning standards.
7. Two (2) full sets of building plans prepared in accordance with the enclosed standards.

PREPARATION OF PLANS

Plans are required to accurately represent the proposed construction. Plans will be reviewed for compliance with the codes and regulations of Miami County before the permit is issued. The more complete the plans the faster the plan review can be performed and the quicker a permit can be issued.

Plans that are incomplete or that require more than one-hour of review time will have plan review fees charged at the rate of \$50.00 per hour with a minimum one-half hour charge. Plan review fees will be added to the permit fee and collected at the time that the permit is issued.

Upon approval of the submitted plans, the plans will be stamped "REVIEWED FOR COMPLIANCE" and the permit will be authorized for issuance. One set of stamped "REVIEWED FOR COMPLIANCE" plans will be returned to the applicant with the permit. The permit applicant is responsible to have approved plans on the job site for all inspections and all site construction is required to be performed in accordance with the approved plans. Revisions to the approved plans must be reviewed and be approved by the building inspection department prior to the revised work being performed.

A brief outline of the details and specifications that the plan reviewer will be checking follows this introduction and an applicant may utilize this outline as a checklist to ensure that they have complied with all the necessary information for submittal with the permit application. If this information is not provided the permit application will be deemed to be incomplete and the plans will be returned to the permit applicant for correction. Upon re-submittal, the plans will be re-reviewed for compliance with the codes and regulations of Miami County.

SITE PLAN REQUIREMENTS

Please refer to the Site Plan Standards handout available from the Planning and Zoning Department.

Site plans that do not show the information that is requested will be rejected during plan review and the site plan will be required to be prepared to acceptable standards, either by an individual or by a registered surveyor.

DESIGN LOADS

The following design loads shall be used in the preparation of the building plans:

- ◆ Ground Snow Load: 20 psf
- ◆ Roof Snow Load: 20 psf
- ◆ Wind Load: 115 mph, exposure "C" for a 3-second gust
- ◆ Seismic Design Category: "A"

PREPARATION OF BUILDING PLANS

Building plans shall provide details and specifications on all of the following that apply:

Floor Plan:

- The use of each separate area of the building shall be shown.
- The overall building dimensions and all separated interior area dimensions shall be shown.
- Ceiling heights shall be shown.

- Location of Exterior Doorways and Windows with Opening Dimensions.
 - Show the location of exterior doors and windows showing the finished opening dimensions
- Location of Plumbing Fixtures shall be shown (if applicable).
- Location of any heating or cooling equipment shall be shown (if applicable).
- Location of electrical service shall be shown with the following information provided (if applicable):
 - Show the location of the electrical service
 - Specify amperage rating of service

Post Frame Structural Details:

Plans for post frame buildings for agricultural or single family accessory use shall show the following.

- ◆ Show the depth of post embedment into the earth as required by Section 9-207 (f)(2).
- ◆ Show required footing diameter per Table 9-207 .1.
- ◆ Show the method of anchoring of post as described by Section 9-207 (f)(6).
- ◆ Show the size of posts as required by Table 9-207.2.
- ◆ Show post layout and spacing per Table 9-207.2.
- ◆ Show the exterior wall height.
- ◆ Show wall girt dimensions and spacing in accordance with Table 9-207.3.
- ◆ Show the type of roof framing and specify spacing of roof members. When trusses are to be used provide a copy of the truss design that bears a seal from a Kansas Registered Engineer.
- ◆ Truss design plans shall provide the allowed spacing, design loads, and top and bottom chord bracing requirements.
- ◆ If trusses are not supported on each post, specify the size of header required to support intermittent trusses.
- ◆ Show the size and spacing of purlins per Table 9-207.4.
- ◆ Show the type of wall and roof coverings.
- ◆ If building is to be separated into different areas, a floor plan indicating the use of each separate area shall be submitted.

Truss Design Requirements

Truss construction documents shall be prepared by a design professional registered in the state of Kansas, and shall be submitted to the codes department for review and approval prior to installation. Submitted truss shop drawings shall indicate, at a minimum, the information specified below:

1. Slope or depth, span and spacing.
2. Location of joints.
3. Required bearing widths.
4. Design loads as applicable.
5. Top chord live load (including 20 lb psf snow load).
6. Top chord dead load.
7. Bottom chord live load.
8. Bottom chord dead load.
9. Concentrated loads and their points of application.
10. Controlling wind loads (minimum 115 mph, exposure C, unless terrain or physical structure is present on property to reduce to exposure B).
11. Adjustments to lumber and metal connector plate design values for conditions of use.
12. Each reaction force and direction.
13. Metal connector plate type, size, thickness or gage, and the dimensioned location of each metal connector plate except where symmetrically located relative to the joint interface.
14. Lumber size, species, and grade for each member.

15. Connection requirements for:
 - 15.1. Truss to girder
 - 15.2. Truss ply to ply
 - 15.3 Field Splices
16. Calculated deflection ratio and/or maximum deflection for live and total load.
17. Maximum axial compression forces in the truss members to enable the building designer to design the size, connections and anchorage of the permanent continuous lateral bracing. Forces shall be shown on the truss construction documents or on supplemental documents.
18. Required permanent truss member bracing location.

9-207 POST FRAME BUILDING STANDARDS.

(a) TITLE. This section shall be known as the Miami County Post Frame Building Standard.

(b) SCOPE. The provisions of this section shall apply to the design and construction of post frame buildings or additions thereto, intended for agricultural or residential accessory uses on tracts of property that are zoned for residential or agricultural uses. The provisions of this article are deemed to comply with the spirit and intent of the minimum design and construction provisions of the 2018 Edition of the International Building Code. Miami County offers no warranty or guarantee on buildings utilizing these design specifications.

(c) LIMITATIONS. Buildings designed and constructed under these provisions shall not exceed limitations of this Section.

Buildings that exceed the limitations of Sections 9-207 (c) (1) through 9-207 (c) (7) shall be designed in accordance with requirements of the 2018 editions of the International Building Code by a professional licensed by the State of Kansas to practice in the design of buildings.

(1) AREA. Buildings shall not exceed 3,000 square feet in area

EXCEPTION: Agricultural Buildings shall not be limited in area.

(2) USE. Buildings designed and constructed under these provisions shall be limited for use as storage or agricultural buildings.

Buildings designed and constructed under the provisions of this standard are not intended for residential or commercial purposes. Post frame buildings intended for residential or commercial use shall have structural and architectural plans prepared by a design professional licensed by the State of Kansas showing compliance with the applicable codes and standards for the proposed use and occupancy.

(3) HEIGHT. The sidewall height of buildings designed under these provisions shall not exceed 14 feet or one story in height.

(4) BUILDING DIMENSIONS. The maximum width dimension of a building designed under these provisions shall not exceed 40 feet.

(5) BRACED WALL. Buildings shall be provided with exterior braced walls. Bracing shall be located in the sidewalls at each corner by means of a nominal 2inch by 4 inch diagonal brace or other approved bracing.

(6) OPENINGS IN EXTERIOR WALLS. No single opening for doors, windows or other purposes that exceed 16 feet in width shall be placed in exterior walls.

Buildings that are open on one side shall have posts embedded 2 feet deeper than the depth required by Section 9-207 (f) (2) or shall be provided with an acceptable brace for wind resistance.

(7) EXIT REQUIRED. At least one exit door complying with this section shall be provided. Exit doors shall be of the pivoted or side hinged swinging type. The exit door opening shall be of a size to permit the installation of a door not less than 3 feet (914 mm) in width and not less than 6 feet 8 inches (2032 mm) in height. The exit door shall be openable from the inside without the use of a key or any special knowledge or special effort.

(d) DEFINITIONS:

AGRICULTURAL BUILDING is a building that is used solely for the storage of machinery, equipment, shelter for livestock or commodities that are raised on site, or other operations related to carrying on the farming operations on a tract of land of twenty (20) contiguous acres or more in area.

BRACED WALL is a wall that has been provided with diagonal bracing which meets the requirements of Section 9-207 (g) (5) of this code.

BUTT ENCASED is concrete encasement of a pole or post at the lower 12 inches of its embedment in the earth.

FOOTING is that portion of the foundation that spreads and transmits loads directly to the soil.

GIRT is the horizontal wall framing members that span between posts and are used to support the exterior wall covering.

POLE OR POST is a preservative treated round, square or rectangular wood member, that is solid sawn or laminated, and is intended to be embedded in the ground to support building structural loads and transmit the loads to the footing.

PURLIN is the structural members that span between rafters or trusses used to attach and support metal roof coverings and transfer the roof loads to the rafters or trusses.

(e) DESIGN LOADS.

(1) LIVE LOAD. The roof snow load shall be 20 pounds per square foot.

EXCEPTION: Agricultural Buildings

(2) DEAD LOAD. The roof dead load shall be 4 lbs. per square foot for roofs that utilize a metal roof covering. Dead Loads of 7 lbs. per square foot shall be used if wood shakes, wood shingles or asphalt composition shingles are utilized. If other roof coverings are used the loading specified by the roof covering manufacturer shall apply.

EXCEPTION: Agricultural Buildings

(3) WIND LOAD. Buildings designed and constructed under these provisions shall be considered to be designed for a 115 mph wind located in an exposure C wind zone.

(4) FOUNDATION DESIGN. Foundations for buildings designed and constructed under provisions of these requirements shall be designed and installed in accordance with this section. Foundations shall be designed to support the imposed load and be capable of resisting wind uplift and overturning. The loading requirements that shall be applicable for buildings designed and constructed under these provisions shall be as specified in this section.

(f) FOUNDATION DESIGN

(1) Foundation Diameter. The diameter of holes for pole or post foundations and the required footing thickness shall be in accordance with Table 9-207.1 Footings shall be placed to a depth so that building loads are supported on natural undisturbed soils. Unless unusual site conditions exist soils bearing capacity shall be assumed to have a 1,500 p.s.f. bearing capacity.

**TABLE 9-207.1
MINIMUM FOOTING DIMENSIONS**

BUILDING WIDTH	POST SPACING	FOOTING THICKNESS	FOOTING DIAMETER
24	8 to 10 Feet	8 Inches	15 Inches
30	8 to 10 Feet	8 Inches	17 Inches
36	8 to 10 Feet	8 Inches	18 Inches
40	8 to 10 Feet	8 Inches	18 Inches

(2) **POLE OR POST EMBEDMENT.** Poles or posts shall be embedded in the earth to a minimum depth of 4 feet (1219 mm).

(3) **SHALLOW POLE OR POST EMBEDMENT.** When it is necessary to use a pole or post embedment depth of less than 40 inches but not less than 30 inches due to rock or other local site conditions, knee bracing shall be provided and the post foundation hole shall be backfilled to grade with concrete. Embedment depth of less than 30 inches is not allowed under this standard.

(4) **BACKFILL.** Footings of concrete, 1 inch or larger gravel or other approved materials shall be placed under poles or posts. Footings shall have a minimum thickness in accordance with Table 9-207.1. Posts shall be either butt encased with concrete, or be fully embedded with concrete, or be provided with other approved means to provide for resistance to wind uplift. If posts are provided with butt encasement or blocked anchors, the remaining annular space of the post foundation holes shall be backfilled by firmly tamping clean soil or sand in maximum 8-inch layers.

See Figure 9-207.1 (a) through (c) for examples of allowed methods of providing uplift resistance and backfilling post holes.

(5) **CONCRETE PLACEMENT.** Concrete used for footings or post encasement shall be placed as wet mix.

(6) **POLE OR POST ANCHOR.** Poles or posts shall be anchored to the encasing concrete whether butt encased or fully encased, with a minimum 1/2 inch reinforcing bar placed through a drilled hole in the pole or post. The rebar shall have a minimum one (1) inch of concrete cover from the bottom and top of the encasing concrete.

Blocked anchors shall be provided when the backfill of the annular space consists of earth, sand or gravel tamped in 8 inch layers. Blocked anchors shall be of the same dimension as the base of the post.

(g) WALL CONSTRUCTION

(1) **POLE OR POST SIZE AND SPACING.** Poles or posts may be solid sawn or laminated. Poles or posts shall be of a minimum dimension as required by Table 9-207.2 based upon the building height and spacing of posts. The spacing of poles or posts shall not exceed the maximum shown in Table 9-207.2 for the dimension of post that will be used.

(2) **WOOD SUBJECT TO DECAY OR TERMITE DAMAGE.**

(A) **WOOD EMBEDDED IN GROUND OR CONCRETE.** Wood embedded in the ground or in direct contact with the earth and used for the support of permanent structures shall be treated for ground contact. Wood supporting permanent structures that are embedded in concrete in direct contact with earth or embedded in concrete exposed to the weather shall be treated for ground contact. Wood which is in contact with the ground shall be treated for ground contact. All treated wood shall bear a stamp from an approved agency identifying the treatment retention of the member.

NOTE: It is recommended that any wood that is embedded in the earth or embedded in concrete that is in direct contact with the earth be pressure preservative treated to a retention level of 0.6 lbs. per cubic foot in accordance with AWPA Standard C22.

(B) WOOD IN CONTACT WITH THE EARTH OR SUBJECT TO WATER SPLASH. Wood that is in contact with the ground or is located within 18 inches of the ground surface shall be pressure preservative treated or wood of natural resistance to decay and termites.

**TABLE 9-207.2
POST SIZE AND SPACING REQUIREMENTS**

POST SIZE ²	EFFECTIVE BUILDING HEIGHT IN FEET ¹			
	8	10	12	14
POLE OR POST SPACING IN FEET				
Solid Sawn				
4 X 4 Nominal	7	6	4	4
4 X 6 Nominal	15	12	9	8
6 X 6 Nominal	15	15	15	15
Laminated				
2-2X6 Laminated	7	6	4	4
3-2X6 Laminated	15	14	10.5	10
4-2X8 Laminated	16	16	16	16

¹ For roof slopes 4:12 or less, the effective height is the vertical distance from grade level to the eave. For roof slopes greater than 4:12 the effective building height is the vertical distance from grade level to the eave, plus one half of the roof height.

² The larger post dimension shall be in the same direction of the building width.

(3) GIRT FRAMING. When siding is to be attached to the exterior walls of pole or post framed buildings, wall girts shall be installed. Wall girts shall be of a minimum size for the span as required by Table 9- 207.3

**Table 9- 207.3
WALL GIRT SPANS**

Girt Span		
8 feet	10 feet	12 feet
2X4 24 inches O.C. 2X6 36 inches O.C.	2X6 36 inches O.C.	2X6 36 inches O.C.

(4) GIRT NAILING. Girts shall be fastened to the posts using 16d ring shank hot dipped galvanized nails or other approved fasteners.

(5) BRACING. Exterior sidewalls shall be braced at building corners. Braces shall be minimum 2X4 nominal dimension lumber installed diagonally or be of other approved bracing materials.

(6) EXTERIOR WALL COVERING. Exterior wall coverings, when provided, shall be of an approved weather-resistant material. Steel panel exterior wall coverings shall be of minimum 29 gage.

(7) HEADERS AND BEAMS. Headers or beams required to support building loads shall be designed to safely carry the imposed loads.

(8) BEAM SUPPORT. Beams, headers or girders that are used to support roof framing shall be supported by notches in the poles or posts and shall be secured by ½ inch diameter bolts secured with washers and nuts or ½ inch by 4 ½ inch lags.

(9) FASTENERS. Fasteners for pressure-preservatively treated wood and fasteners used in locations exposed to weather shall be of hot-dipped zinc galvanized, aluminum alloy wire fasteners or stainless steel fasteners.

(h) ROOF CEILING CONSTRUCTION

(1) GENERAL. Roof framing may be of conventional light frame construction as allowed by Chapter 23 of the *International Building Code*®, 2018 edition or may be of trusses as specified by Section 9-207 (h) (2) of this code or may be of other alternate designs that have been designed by a professional engineer licensed by the State of Kansas.

(2) TRUSSES. Trusses may be site built or be shop fabricated. Trusses shall be designed by a professional engineer licensed by the State of Kansas to practice in the design of buildings.

(3) CONVENTIONAL FRAMING. The framing details for conventional roof construction shall conform to the requirements of Chapter 23 of the *International Building Code*®, 2018 edition.

(4) ROOF-MEMBERS-TO-BUILDING-FRAME TIE. Blocking, straps, approved framing anchors or mechanical fasteners shall be installed from the side of the roof framing member to the exterior posts or other supporting members.

Tie straps shall be 1 1/8-inch (28.6 mm) by 0.036-inch (0.91 mm) (No. 20 gage) sheet steel and shall be corrosion resistant.

(6) PURLINS. Purlins shall be installed with the wide dimension perpendicular to the load that it supports. Purlins shall be supported on top of the trusses or shall be provided with approved hangers. The span of purlins shall not exceed the values specified in Table 9-207.4.

(7) ROOF COVERING. The roof covering shall be of an approved material as specified by Chapter 15 of the *International Building Code*®, 2018 edition.

**TABLE 9-207.4
PURLIN SPANS**

(Based on Purlin Spacing of 24 inches Center to Center)

GRADE	DIMENSION	MAXIMUM SPAN (feet)
#1	2X4	8' 6"
	2X6	12' 3"
	2X8	15' 9"
#2	2X4	8'
	2X6	12'
	2X8	15'
#3	2X4	6'
	2X6	9'
	2X8	11'

FPN: The spans given in this table are based upon use of Spruce-Pine-Fir design values. Spans may vary depending on the lumber species which is used.

FIGURE 9-207.1
Examples of Post Embedment

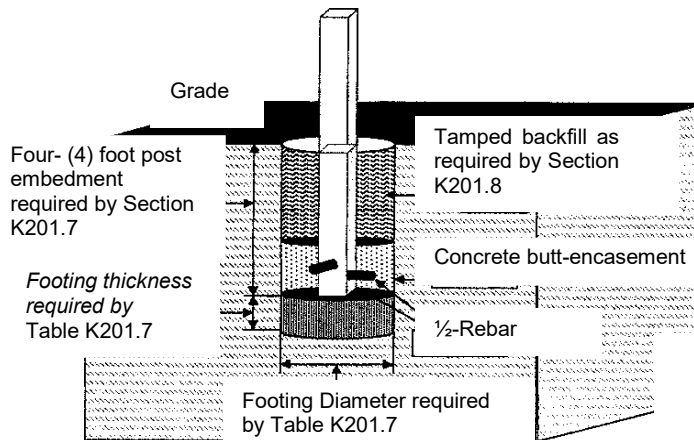

FIGURE 9-207.1 (a)
Butt-Cased

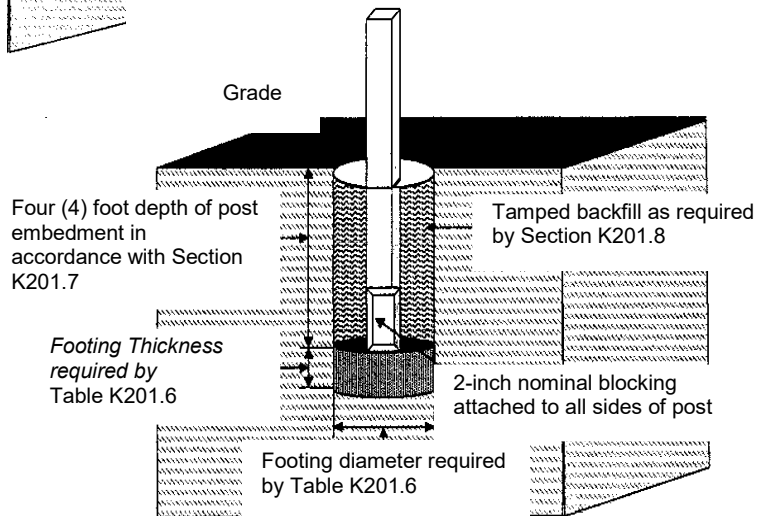

FIGURE 9-07(b)2
Blocked Anchor

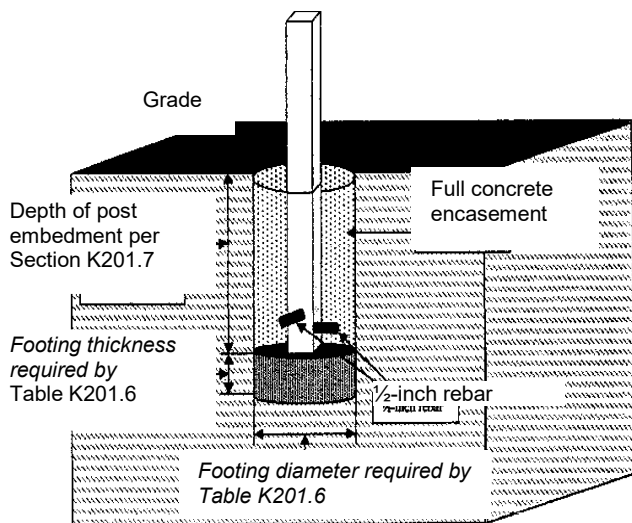
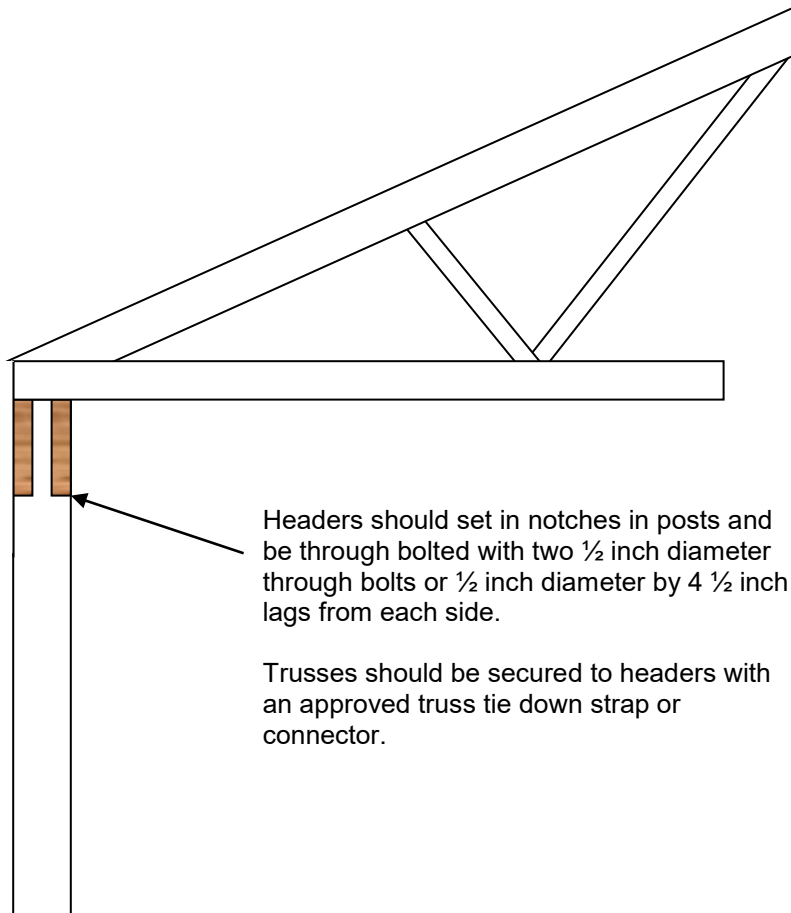

FIGURE 9-207 (c)
Full Concrete Casement

ILLUSTRATION OF HEADER SUPPORT AND TRUSS TIE DOWN



Example of approved truss tie down connector

RT3
Hurricane/Seismic Anchor

Ref.# H3/H4

Code Listings:
NER 505
ICBD ES ER-5736
LA CITY RR 25303
DADE CD 02-0128.05
ISA PA-076
FL816

Fasteners
Supporting Member: (4) 8d Nails
Supported Member: (4) 8d Nails

USP Structural Connectors™
©Copyright 2004 United Steel Products Company

RT3
Hurricane/Seismic Anchor

Ref.# H3/H4

Code Listings:
NER 505
ICBD ES ER-5736
LA CITY RR 25303
DADE CD 02-0128.05
ISA PA-076
FL816

Fasteners
Supporting Member: (4) 8d Nails
Supported Member: (4) 8d Nails

USP Structural Connectors™
©Copyright 2004 United Steel Products Company

FREQUENTLY ASKED QUESTIONS

Q. Are the plans required to be prepared or be sealed by an architect?

A. Generally, plans for construction work involving single family use buildings are not required to be prepared by an architect or engineer, however, some special design features or construction methods that are not covered by the prescriptive requirements of the applicable codes may require a design to be prepared by a Kansas Registered Design Professional. Some of the special features or construction methods that do require plans to be prepared by a design professional include truss system design, structural slabs and rigid steel frame building design including the supporting foundation systems.

Q. How long does it take to obtain a building permit?

A. A full review of the plans and specifications will be completed by the departments and agencies responsible for checking the project for compliance with applicable codes and regulations. Depending on the complexity of the project and completeness of plans and specifications an answer usually can be given within five working days. **During peak construction periods this time frame may be exceeded** so please allow ample time when making application for a building permit.

Please keep in mind that the more concise and complete your plans are, the faster it is to complete the review of your project and the easier it is for us to help you prevent costly errors and omissions once your project is underway.

Q. How close to a property line can I construct a building?

A. The minimum setbacks depend on the Zoning District in which the parcel of land is located. Contact the Planning and Development Department at (913) 294-9553 for details and have the legal description, including the Section, Township and Range of the property available when calling.

Q. How is my property zoned? What uses are allowed on the property?

A. Contact the Planning and Development Department at (913) 294-9553 for details and have the legal description, including the Section, Township and Range of the property available when calling.

Q. What work requires licensed contractors?

A. Generally, property owners may perform any type of work on buildings that they own and will personally occupy. Individuals or companies that act as building contractors in Miami County are required to be licensed. Licensing is required for general contractors, electrical contractors, plumbing contractors, HVAC contractors, foundation contractors, roofing contractors and site utility installers.

Q. What codes have been adopted by Miami County?

A. Miami County currently enforces the provisions of the 2018 edition of the *International Residential Code* for One and Two Family Dwellings®, 2018 edition of the *International Building Code*®, the 2018 edition of the *International Plumbing Code*®, the 2018 edition of the *International Mechanical Code*®, the 2018 edition of the *International Fire Code*®, the 2018 edition of the *International Swimming Pool and Spa Code*® and the 2017 edition of the *National Electrical Code*®.

Q. Where can I obtain a copy of the Building Codes adopted by Miami County?

A. Copies of the Uniform Codes or the International Residential Code may be obtained from the International Code Council by phone at 1-800-786-4452 or can be ordered online at www.iccsafe.org/store.

Q. What will my building permit cost?

A. Permit fees are based upon the valuation of construction. The valuation will be determined as part of the plan review process and there is no standard answer, the fee is based upon factors such as the square footage of the dwelling, basement, finished basement and garages along with other factors. A worksheet for an individual to estimate a permit fee is available from the building inspection department.

Q. What type of inspections are required?

A. A complete listing of required inspections will be included with the building permit. A related handout is available on request outlining required inspections and procedures for making inspection requests. A typical residential accessory building can have as few as two inspections, however, additional inspections may be required based upon the type of work that is being performed. Typical inspections include footings, foundation walls, under slab plumbing, rough-in of building, electrical, plumbing and hvac systems, open trench inspections for electrical, water and gas laterals, interior gas piping installation and pressure testing, and a final inspection.

Q. When can a new building be used or occupied?

A. Generally anything that is considered to be a safety or sanitation requirement must be complete before occupancy of a new building will be granted. A Certificate of Occupancy is required to be issued by the Codes Official before a building may be legally occupied. A final inspection is required prior to gaining approval to use or occupy any building.

Q. Can a dwelling unit be constructed in an accessory building?

A. If the structure is designed for the loads and conditions for residential use the building may be allowed to have a dwelling unit finished inside of it. When the building is either of post frame or rigid steel frame construction the structural plans will be required to be prepared and sealed by a design professional registered by the state of Kansas providing details and specifications showing the required compliance with the provisions of the International Building Code for use as a residential structure.